

UDK 621.317.25

A SIMPLE PRECISION MODULUS FOR TEMPERATURE MEASUREMENTS

Yevdokimov S. V., Sapiga A. A., Pritulenko A. S., Yatsenko A. V.

Taurida National V. I. Vernadsky University, 4 Vernadsky Ave., Simferopol 95007, Ukraine
E-mail: lab2@crimea.edu

We report on a simple low-cost modulus for precision temperature measurements. This device consist of a precision 4½ digit microvoltmeter with a full scale ± 20 mV with absolute 1 μ V accuracy and additional digital controller of the room temperature (accuracy is equal to 0,1 °C). Proposed device can be successively utilized in the process of investigation the different magnetic and electrical properties of solids versus temperature or in the processes of technological high-temperature treatments of the crystals.

Keywords: thermometry, microvoltmeter.

PACS: 84.30. $\pm r$

INTRODUCTION

Studies of a physical properties of ferromagnetic and, especially, ferroelectric materials requires usually the stabilization of the temperature of the investigated sample or its changing according to a necessary algorithm [1, 2]. For the temperature measurements in the range (77 ÷ 370) K semiconducting temperature sensors are widely used due to a high sensitivity and good linearity of their characteristics [3]. In the cases when the temperature of the sample under investigation is higher than 380 K, only thermocouples can be used for the temperature measurements, but their sensitivity is small – in the best case it equal to (50 - 80) μ V/°C [4].

In order to measure the electromotive force, generated by thermocouple, the professional digital nano- or microvoltmeters, which provides the absolute accuracy not worse then 1 μ V are use usually. When a well calibrated thermocouples are used, this decision is a quarantee of the possibility of precision measuring of the temperature of investigated sample. In spite of these, in some cases more reliable is the exploiting of a simple specialized devices, which realized by using of modern commercially available integral circuits. The simple low-cost device which realize the measurements of dc voltage in the range of ± 20 mV with 1 μ V absolute accuracy and the control of the room temperature with 0,1 °C accuracy is described below.

TECHNICAL DESCRIPTION

The principal sheme of the designed microvoltmeter is shown in Fig. 1. For the obtaining of high absolute accuracy of measurements we choose ICL7135 chip – a precision 4½ digit analog-to-digital converter (ADC). It is a monolithic ADC with dual-slope conversion and periodic autozeroing, which consist of the multiplexed BCD output and digit drivers too. This choise is caused due to its small temperature drift – not more then 2 μ V/°C and a high temperature stability of a scale factor temperature coefficient, which is equal to 5×10^{-6} /°C [5]. External square-wave generator is realized by a logical IC M₂ for ADC clocking.

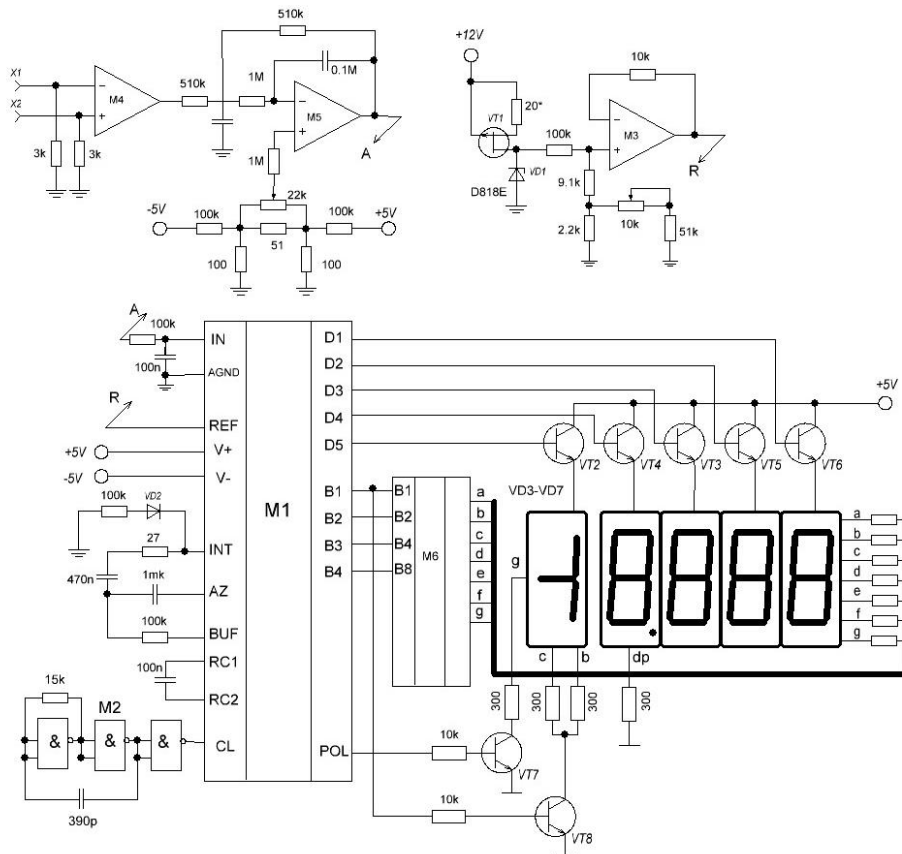

Fig. 1. 4½ digit microvoltmeter. M₁ – ICL7135; M₂ – 4001B; M₃, M₅ – OP07; M₄ – INA131; M₆ – 4543B; VT₁ – KP307B; VT₂-VT₈ – KT3102E; VD₁ – D818E.

Because an external source of reference voltage (+1,0000 V) is need for ADC operation, a precision stabistor VD₁ which supplies through the current source VT₁ by a current of 10 mA and additional voltage divider are used to this aim. Voltage divider is realized by using of precision thermostable resistors R₁-R₄ and operational amplifier M₃.

For the obtaining of high sensitivity of the device and its optimal alignment with a differential thermocouples we use a precision instrumentation amplifier INA131, which characterized by a very low offset voltage (50 μV max), drift (0,25 μV/°C) and high common mode rejection (110 db). Its gain *G* is fixed and is equal to 100 with a gain error no more then 0.01% [6]. For the additional minimization the action of 50Hz supply noise, a 2-nd order low pass filter with 5 Hz cutoff frequency and *G* = 1 is included between the preamplifier's out and analogous input of ADC. This filter is realized by operational amplifiers M₅ which also provides a sharp turning of instrumental “zero”.

Microvoltmeter's digital display is realized by LED matrix VD₂-VD₆ with a common anode and operates by transistor' keys VT₂-VT₈ and by additional digital decoder M₇. It is need to note, that the realization of the control circuits for the oldest decimal digit in LED display is differ of original [5].

An excellent long-term stability of the microvoltmeter is reached by the arrangement of its printed circuit board inside the active cooling thermostatic unit, which keep internal temperature in limits $(14,0 \pm 0,1)^\circ\text{C}$ when the room temperature changes from 14°C to 30°C . Design of the thermostatic unit and its realization were described earlier [7]. Designed microvoltmeter is tuned and calibrate by using certificated B7-21A microvitmeter.

When the temperature measured by differential thermocouples, the method of compensation of a “cold” thermal junction electromotive force is used frequently [3] or localization of the “cold” thermal junction in a media which have a fixed temperature – in a water-ise mixture for example. If the needed accuracy of temperature control is not higher than $0,1^\circ\text{C}$, the most simple solution of a problem can be realized – localization of a “cold” thermal junction and additional semiconducting temperature sensor in a styrofoam cylinder jar. It makes a possible to control the room temperature additionally. Digital controller of the room temperature can be realized by usind of semiconducting temperature sensor and single crystal programmable microcontroller. The principal scheme of this device is presents in Fig. 2. It consist of the programmable resolution digital thermometer M_1 , singlecrystal microcontroller M_2 and specialized LCD display M_3 . Inspite of its simplicity, this controller provides the measurements of the temperature with an absolute accuracy of $0,1^\circ\text{C}$. in $(10 - 30)^\circ\text{C}$ range.

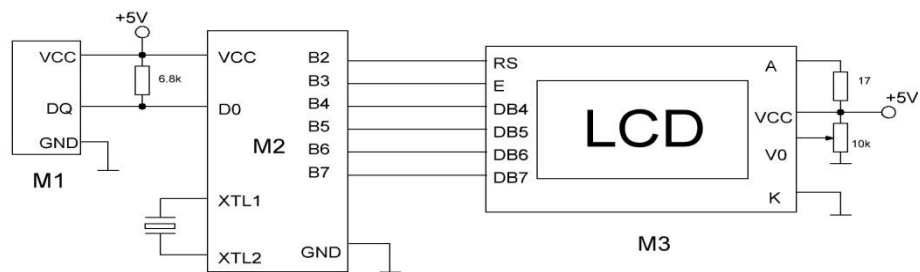

Fig. 2. Digital controller of the room temperature. M_1 – DS18B20; M_2 – ATTINY2313; M_3 – WC0802.

Described device is realized as an autonomous shielded module with $120 \times 80 \times 80$ mm size and for its work are needed two external voltages ± 12 V with a load currents of $0,2$ A, and additional $+6$ V supply voltage with $2,0$ A load current. This module can be implanted into a more complex equipment with using its supply sources.

SUMMARY

The main appointment of designed device is a substitution of old professional microvoltmeters such as B3-21 and ИИ300 which are widely exploited else for the measuring of the temperature by differential thermocouples.

The greatest advantage of designed device in the comparing with another accessible modern professional microvoltmeters is the excellent temperature stability, which excluded the necessitate of “zero” turning under the relatively large changes of the surrounding temperature. It is need to note, that a sensitivity of the device can be increased up to $0,1 \mu\text{V}$, but its full scale will be limited by $\pm 2,0000$ mV only.

References

1. S. V. Yevdokimov, R. I. Shostak, A. V. Yatsenko, *Physics of the Solid State* **49**, 1957 (2007).
2. T. Stankevic, V. Stankevic, D. Pavilonis, N. Zurauskiene, J. Novickij, S. Tolvaisiene, *Electronics and Electrical engineering* **3(119)**, 53 (2012).
3. J. A. Whitston, *500 Electronic IC Circuits with Practical Applications* (Tab books, Blue Ridge Summit PA, 1990).
4. A. Ghosh, *Introduction to Measurements and Instrumentation* (PHI Learning Private Limited, New Dehli, 2009).
5. *ICL7135 datasheet*, www.intersil.com.
6. *Analog Signal Chain Guide* (Texas Instruments Incorporated, 2011).
7. S. V. Yevdokimov, A. A. Yatsenko, A. V. Yatsenko, *Scientific Notes of Taurida National V. I. Vernadsky University, Ser. Physics and Mathematics Sciences* **23(62)**, No. 1, 125 (2010).

Євдокимов С. В. Простий прецизійний модуль для вимірювання температури / С. В. Євдокимов, О. О. Сапіга, А. С. Притуленко, О. В. Яценко // Вчені записки Таврійського національного університету імені В. І. Вернадського. Серія : Фізико-математичні науки. – 2013. – Т. 26 (65), № 2. – С. 158-161.

Наведено опис простого недорогого модуля для вимірювання температури. Пристрій містить 4½ розрядний мікрровольтметр, який працює в діапазоні ± 20 мВ та має абсолютну помилку вимірювання менш ніж 1 мкВ і допоміжний цифровий вимірювач температури навколишнього середовища (точність 0,1 °С). Пристрій може бути використаний у процесах дослідження впливів зміни температури на електричні та магнітні властивості твердих тіл, а також під час проведення високотемпературних технологічних і термохімічних обробок кристалів і магнітних плівок.

Ключові слова: термометрія, мікрровольтметр.

Евдокимов С. В. Простой прецизионный модуль для измерения температуры / С. В. Евдокимов, А. А. Сапига, А. С. Притуленко, А. В. Яценко // Ученые записки Таврического национального университета имени В. И. Вернадского. Серия : Физико-математические науки. – 2013. – Т. 26 (65), № 2. – С. 158-161.

Приводится описание простого недорогого модуля для измерений температуры. Устройство содержит 4½ разрядный микровольтметр, работающий в диапазоне ± 20 мВ с абсолютной погрешностью измерения менее 1 мкВ и дополнительный цифровой измеритель температуры окружающей среды (точность 0,1 °С). Устройство может быть использовано для исследования температурной зависимости электрических и магнитных свойств твердых тел, а также в процессах высокотемпературных технологических и термохимических обработок кристаллов и магнитных пленок.

Ключевые слова: термометрия, микровольтметр.

Список литературы

1. Yevdokimov S. V. Anomalies in the pyroelectric properties of LiNbO₃ crystals of the congruent composition / S. V. Yevdokimov, R. I. Shostak, A. V. Yatsenko // *Physics of the Solid State*. – 2007. – Vol. 49. – P. 1957.
2. Stankevic T. Computer Controlled Thermostat for the Resistivity measurements of the La_{1-x}Sr_xMnO₃ thin films / T. Stankevic, V. Stankevic, D. Pavilonis, [et al.] // *Electronics and Electrical engineering*. – 2012. – No 3(119). – P. 53.
3. Whitston J. A. *500 Electronic IC Circuits with Practical Applications* : Tab books / J. A. Whitston. – Blue Ridge Summit PA, 1990.
4. Ghosh A. *Introduction to Measurements and Instrumentation* // A. Ghosh – 3-rd ed. – New Dehli : PHI Learning Private Limited. – 2009. – 810 p.
5. ICL7135 datasheet [Electronic resource]. – URL : www.intersil.com.
6. *Analog Signal Chain Guide* – Texas Instruments Incorporated, 2011.
7. Yatsenko A. V. Simple amplifier for pyroelectric measurements / S. V. Yevdokimov, A. A. Yatsenko, A. V. Yatsenko // *Scientific Notes of Taurida National V. I. Vernadsky University*. – Series : Physics and Mathematics Sciences. – 2010. – Vol. 23 (62), No 1, Part I. – P. 125-130.

Received 11 June 2013.